



TERRACON BUSINESS PARK

FOR LEASE

4,077 SF FINISHED OFFICE & WAREHOUSE SPACE



Brett Odaisky
bodaisky@terracon.co
(204) 233-4330

Daniel Mills
dmills@terracon.co
(204) 233-4330

27 TERRACON PLACE

FLOOR PLAN

MAIN FLOOR

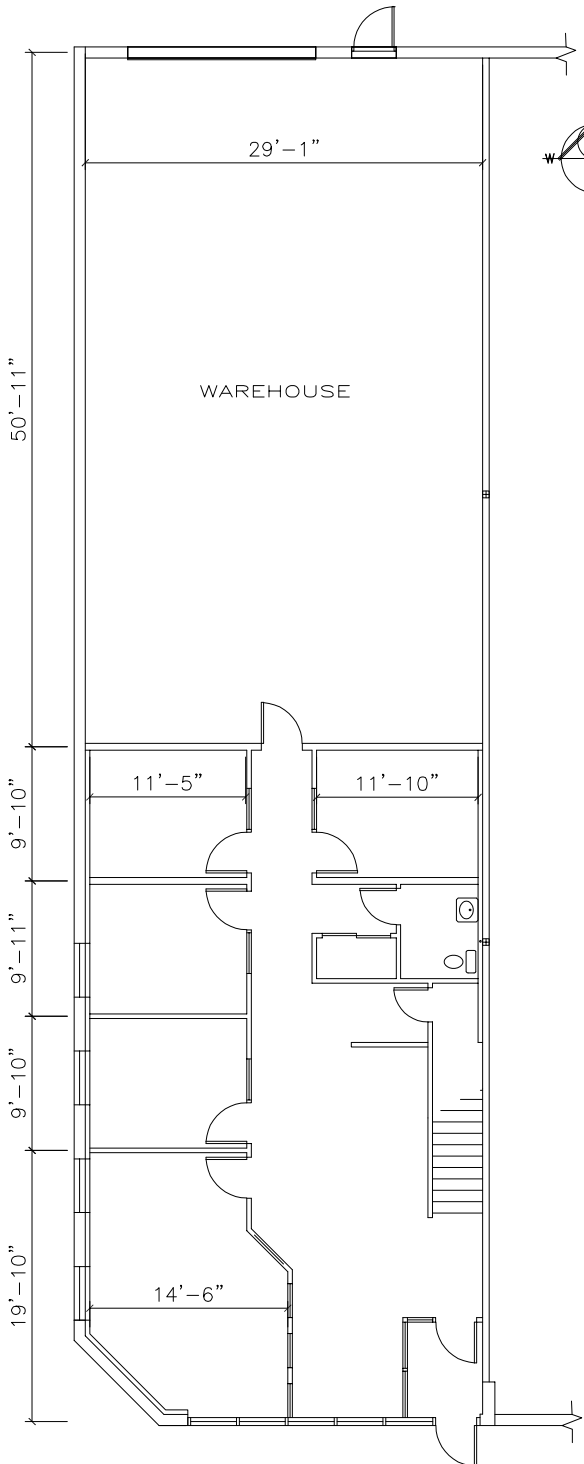

MEZZANINE

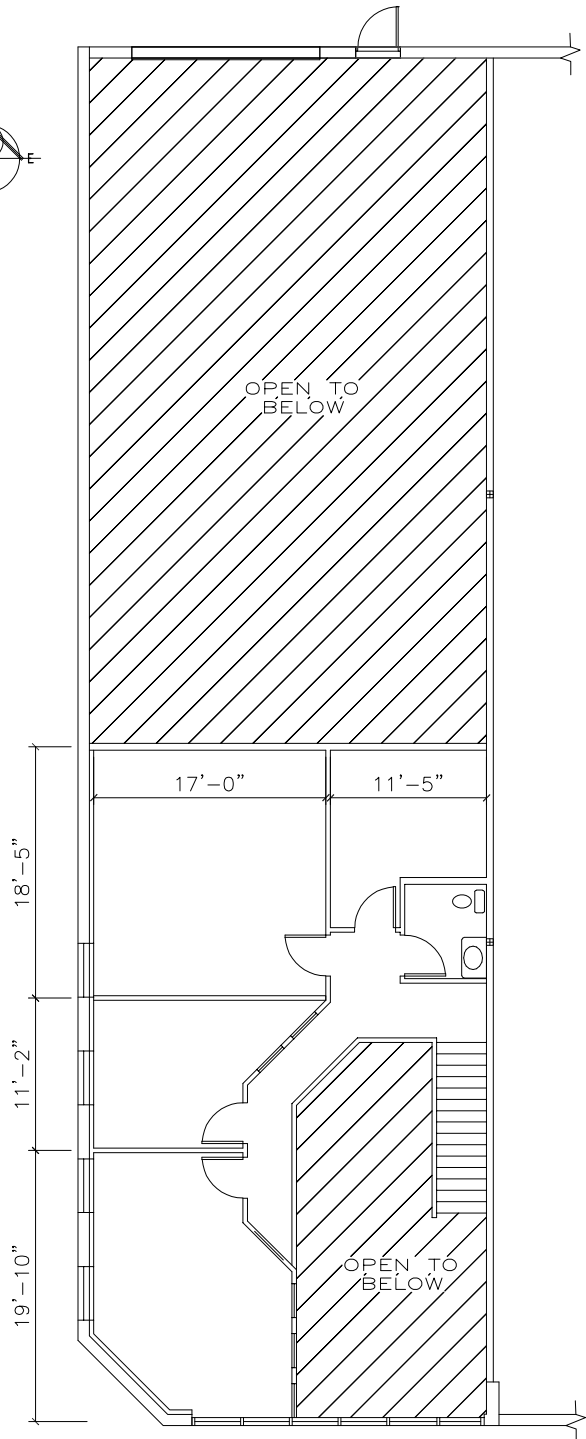

FOR LEASE

INTERIOR PICTURES



PROPERTY SUMMARY

Available Space	4,077 sf
Lease Rate	TBN
Ceiling Height	18' Clear
Loading Area	Grade
Parking Stalls Available	6 stalls*

FEATURES

- End-cap unit
- Finished office and warehouse space
- 1,500 sf first floor office, 1,077 sf mezzanine office & 1,500 sf warehouse
- Common areas extensively landscaped with grass, fountains, lakes, and trees

*Additional parking available





**TERRACON
DEVELOPMENT
LTD.**

**1 Terracon Place
Winnipeg, Manitoba
R2J 4B3
Tel: (204) 233-4330
Fax: (204) 233-5085
info@terracon.co
www.terracon.co**